

Component Dimensions

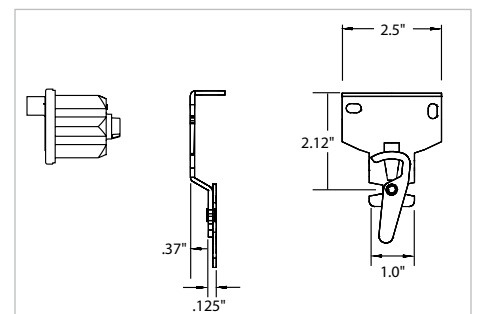
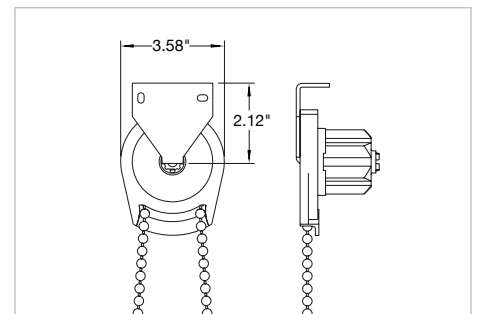
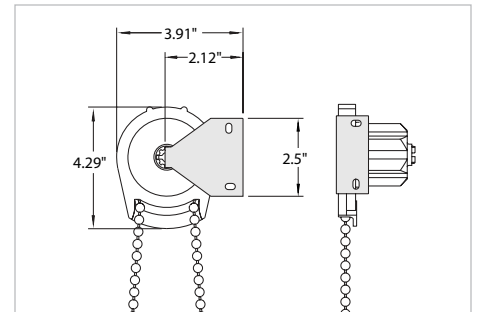

- CR24 clutch system is designed to lift shades weighing up to twenty-four pounds.
- Shades are raised and lowered by means of a #10 stainless steel bead chain.
- Roller tube is extruded aluminum engineered with a channel to accept fabric spline making the shade panel easy to remove.
- Hem bar is extruded aluminum and completely enclosed in a heat-welded hem pocket. Optional fabric wrapped hem bar.
- Edge gap is 5/8" on the clutch end and 5/8" on the idler end.
- Optional lift assist reduces pull force allowing easy lifting of larger shades.