

Data Sheet

STANDARD (60mm) MOTORIZED SHADE WITH BLACKOUT

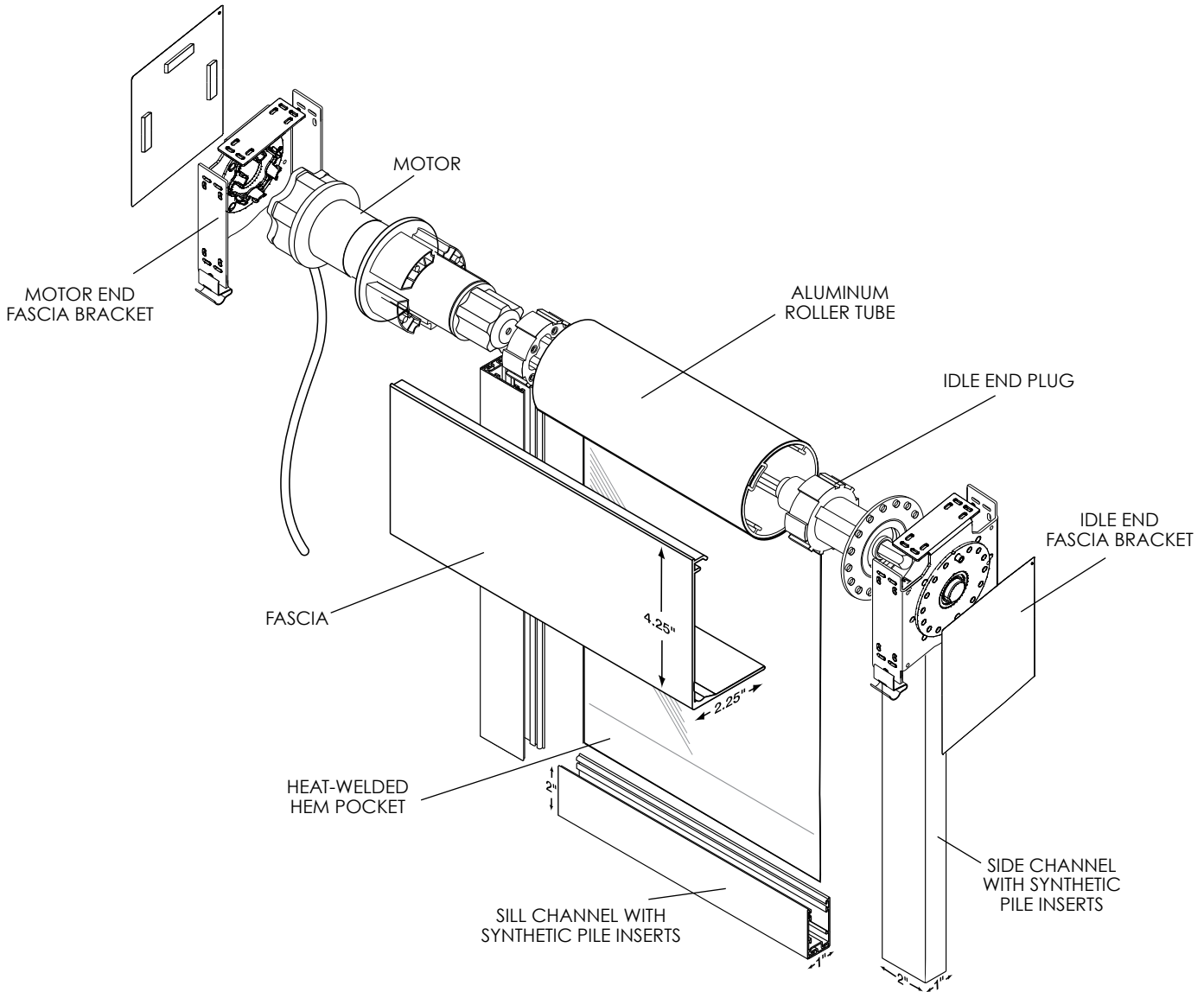

- Shades are raised and lowered by means of a line voltage AC motor.
- All motors come standard with a quick disconnect plug.
- Roller tube is extruded aluminum engineered with a channel to accept fabric spline making the shade panel easy to remove.
- Adjustable idle end bracket allows shades to be leveled while in place.
- Hem bar is extruded aluminum and completely enclosed in a heat-welded hem pocket.
- 4.25" x 2.25" fascia available on line voltage AC motorized systems. Available in white, vanilla, clear anodized, bronze and black. Optional back fascia.
- Side and sill channels are 2" x 1" extruded aluminum with synthetic pile inserts to eliminate light leakage. Available in white, clear anodized or bronze.