

Data Sheet

EXTENDED (80mm) MOTORIZED SHADE WITH FASCIA

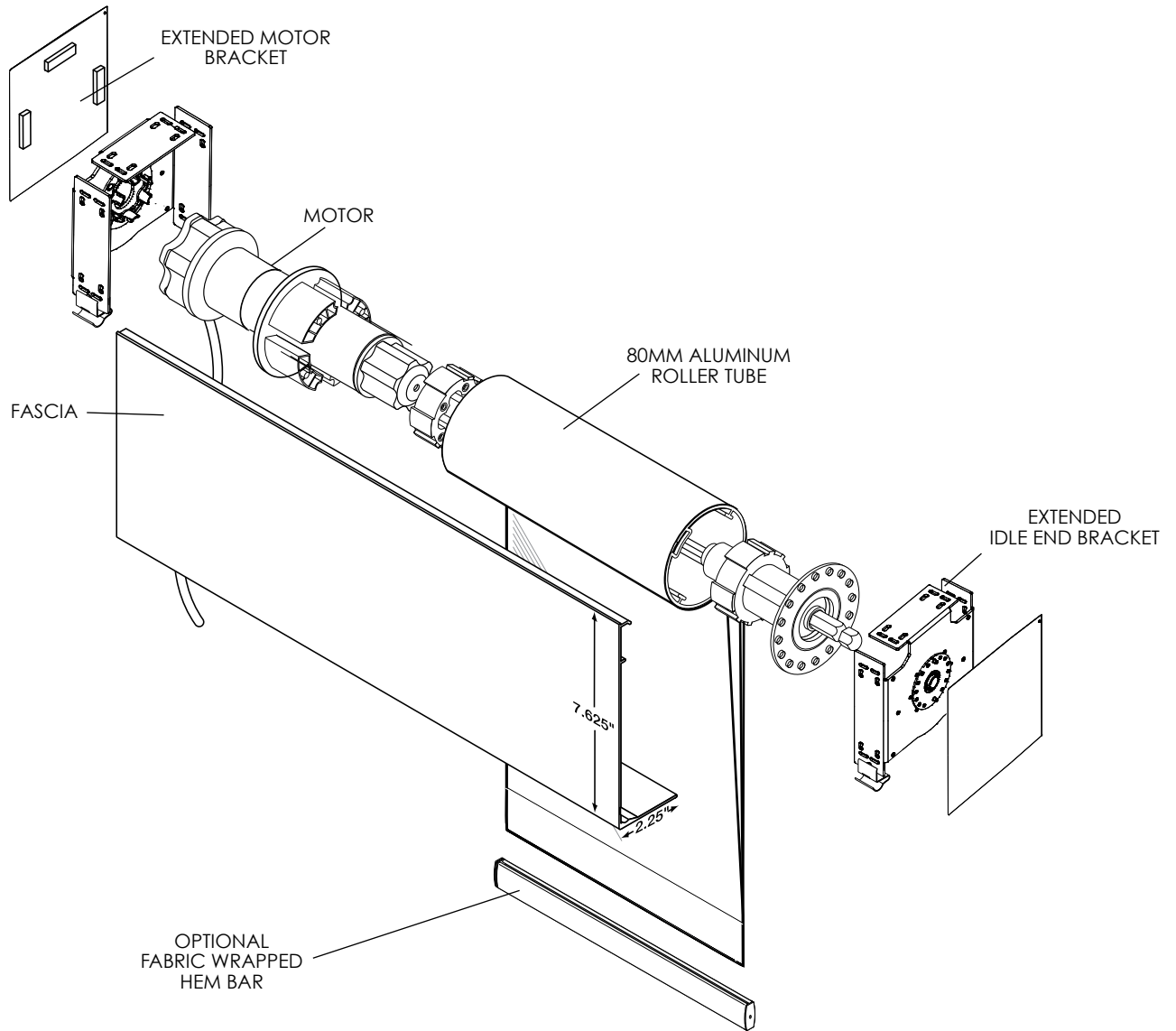

- Shades are raised and lowered by means of a line voltage AC motor.
- All motors come standard with a quick disconnect plug.
- Roller tube is 80mm extruded aluminum for large shade applications and is engineered with a channel to accept fabric spline making the shade panel easy to remove.
- Adjustable idle end bracket allows shades to be leveled while in place.
- Hem bar is extruded aluminum and completely enclosed in a heat-welded hem pocket. Optional fabric wrapped hem bar.
- 7.625" x 2.25" fascia available in white, vanilla, clear anodized, bronze and black.
- Edge gap is 1-1/8" on the motor end and 3/4" on the idle end.